

# Appendix 3:

## Final Design





# Chosen Design General Arrangement



# Tower Hill Play Design **General Arrangement (West)**



## Key

-  **Application Boundary**
-  **Existing trees and RPA**
-  **S02- Tiger mulch (Play safety surface)**  
Allow for removal of top layer of grass, 100mm depth tiger mulch with no edgings, edges feathered in with site won topsoil and seeded.
-  **S03- Resin Bound Gravel path**  
Permeable path 1.2m wide

## Edgings

-  **E01 - Timber edging, thin - pressure treated timber softwood edge boards, 150mm width x 19mm thick, secured using timber softwood pegs at 0.5m centres.**

## Furniture & Fencing

- F01 - Metal railing of 1.2m high**
- F02 - Existing boulders salvaged and re-positioned**
- F03 - Westminster Seat 1.95m- 4 Seater Hardwood Bench**  
<https://www.bransonleisure.com/product/westminster-seat-1-95m/>
- F04 - Self closing double gate**
- F05 - Self closing single gate**
- F06 - Circular Tree Seat**

## Catalogue Play Equipment by Play Equip

- P01 - Nursery Swing**
- P02 - Group Basket Swing**
- P03 - Inclusive Roundabout**
- P04 - Trim Trail**
- P05 - Wide Slide**
- P06 - In-ground Trampoline**
- P07 - Sensory Play**

## Bespoke Play Equipment by Play Equip





- P08 - Fort Play Structure**

-  **Proposed amenity grass turf**  
Cultivated and prepared. DLF seed mix PM 51 Greenscape @ 35g/m<sup>2</sup>.
-  **Proposed low mixed planting**  
Low maintenance native mix, average no. plants per m<sup>2</sup>
-  **UK Native evergreen hedgerow**  
Double staggered UK native evergreen hedgerow.

# Tower Hill Play Design **General Arrangement (East)**



## Key

-  **Application Boundary**
-  **Existing trees and RPA**
-  **S02- Tiger mulch (Play safety surface)**  
Allow for removal of top layer of grass, 100mm depth tiger mulch with no edgings, edges feathered in with site won topsoil and seeded.
-  **S03- Resin Bound Gravel path**  
Permeable path 1.2m wide
- Edgings**
-  **E01 - Timber edging, thin - pressure treated timber softwood edge boards, 150mm width x 19mm thick, secured using timber softwood pegs at 0.5m centres.**

## Furniture & Fencing

- F01 - Metal railing of 1.2m high**
- F02 - Existing boulders salvaged and re-positioned**
- F03 - Westminster Seat 1.95m- 4 Seater Hardwood Bench**  
<https://www.bransonleisure.com/product/westminster-seat-1-95m/>
- F04 - Self closing double gate**
- F05 - Self closing single gate**
- F06 - Circular Tree Seat**

## Catalogue Play Equipment by Play Equip

- P01 - Nursery Swing**
- P02 - Group Basket Swing**
- P03 - Inclusive Roundabout**
- P04 - Trim Trail**
- P05 - Wide Slide**
- P06 - In-ground Trampoline**
- P07 - Sensory Play**

## Bespoke Play Equipment by Play Equip

- P08 - Fort Play Structure**

-  **Proposed amenity grass turf**  
Cultivated and prepared. DLF seed mix PM 51 Greenscape @ 35g/m<sup>2</sup>.
-  **Proposed low mixed planting**  
Low maintenance native mix, average no. plants per m<sup>2</sup>
-  **UK Native evergreen hedgerow**  
Double staggered UK native evergreen hedgerow.

# Play Equipment **Bespoke Fort Play**

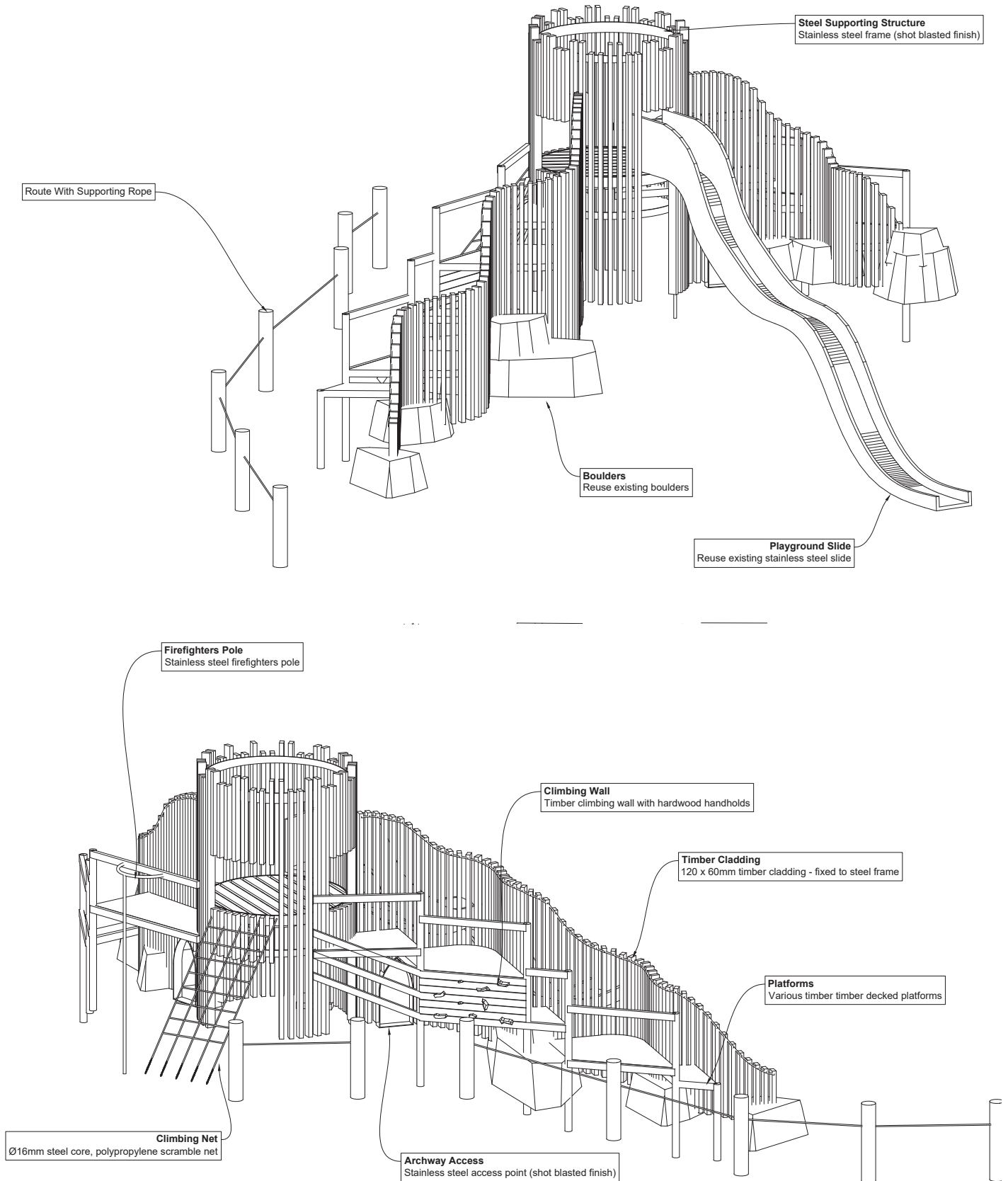

# Play Equipment Bespoke Fort Play

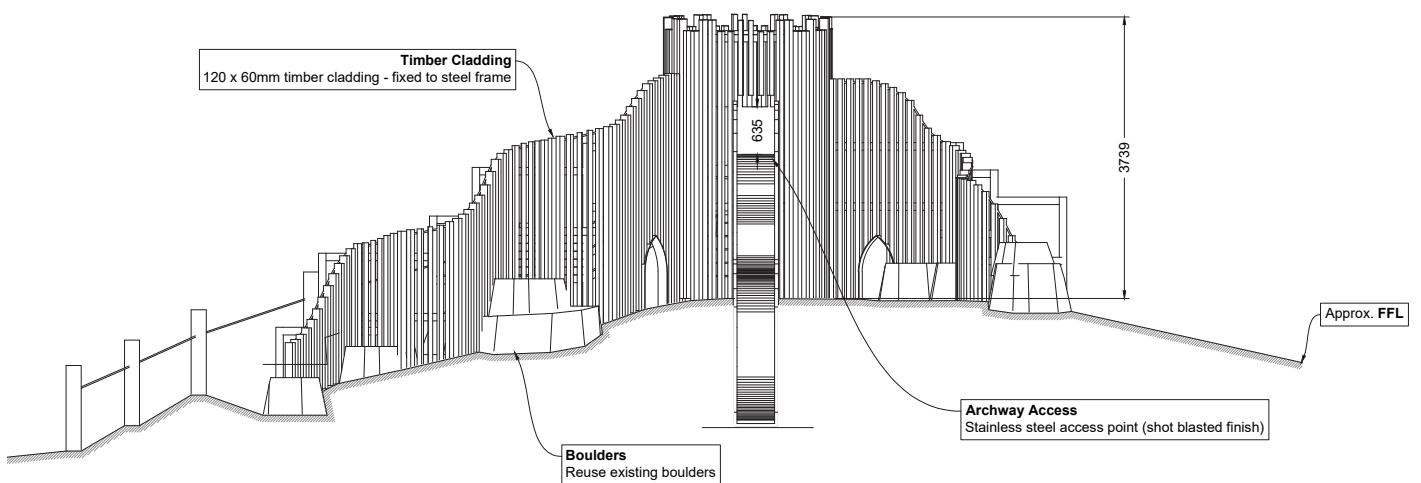
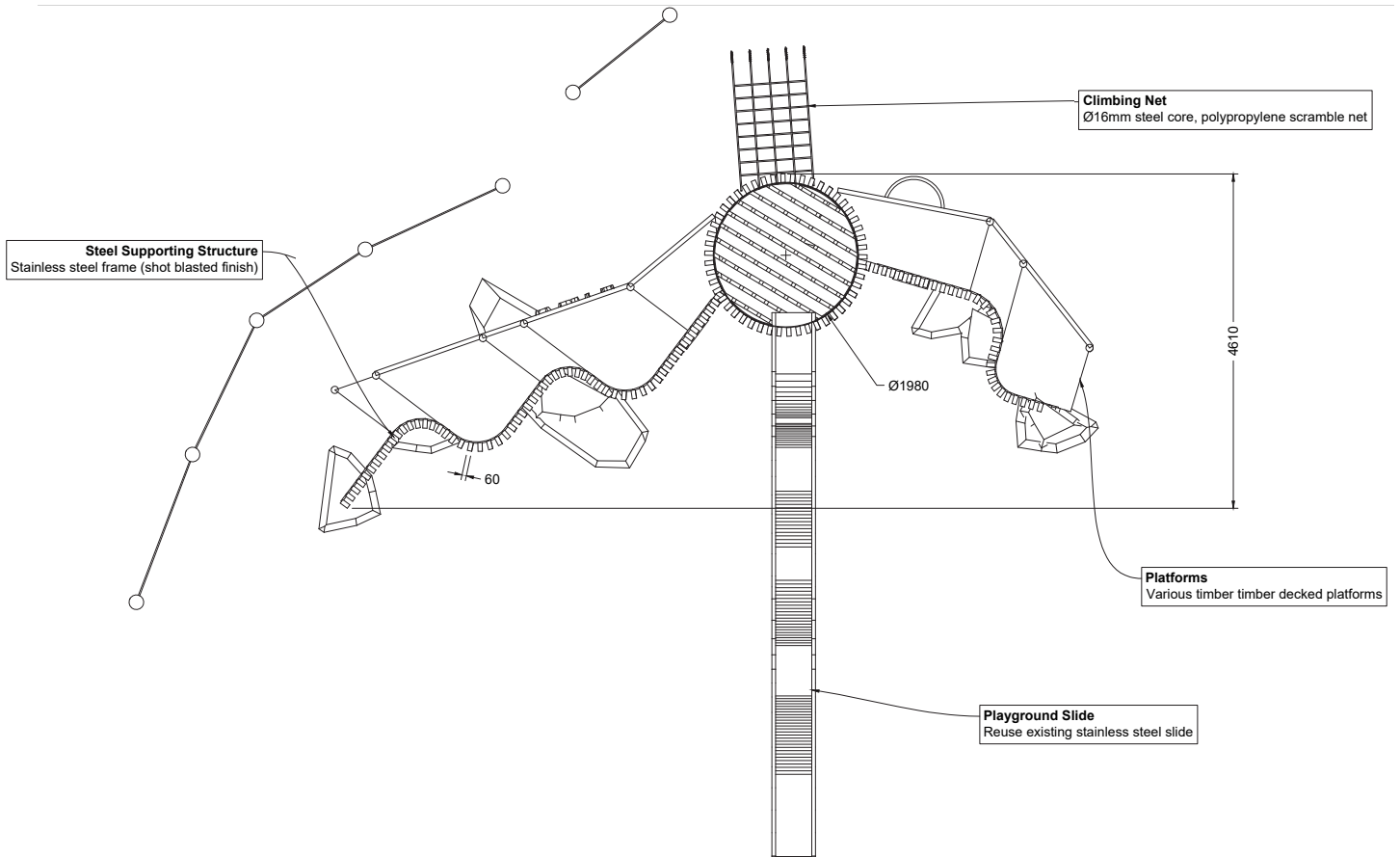

is specified otherwise



# Play Equipment Bespoke Fort Play- Fort Play/ Seat

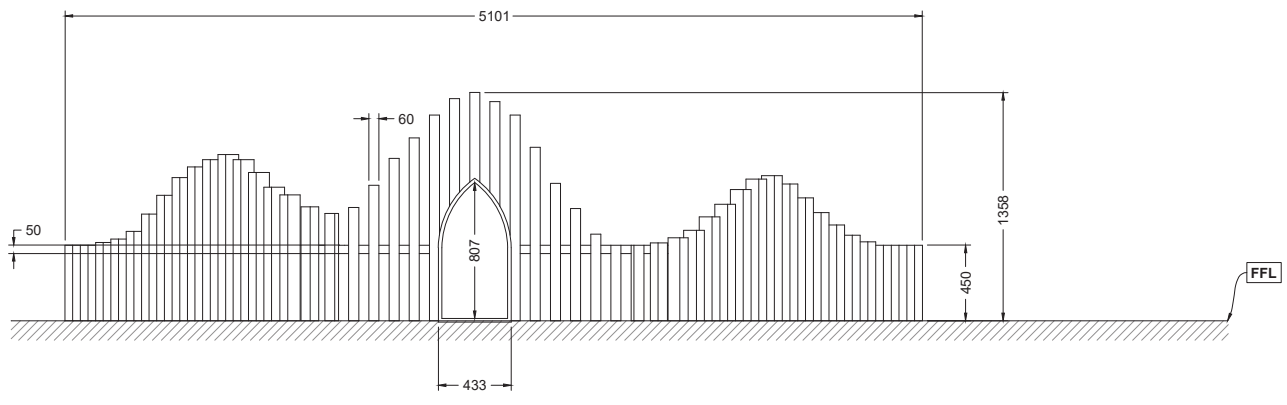
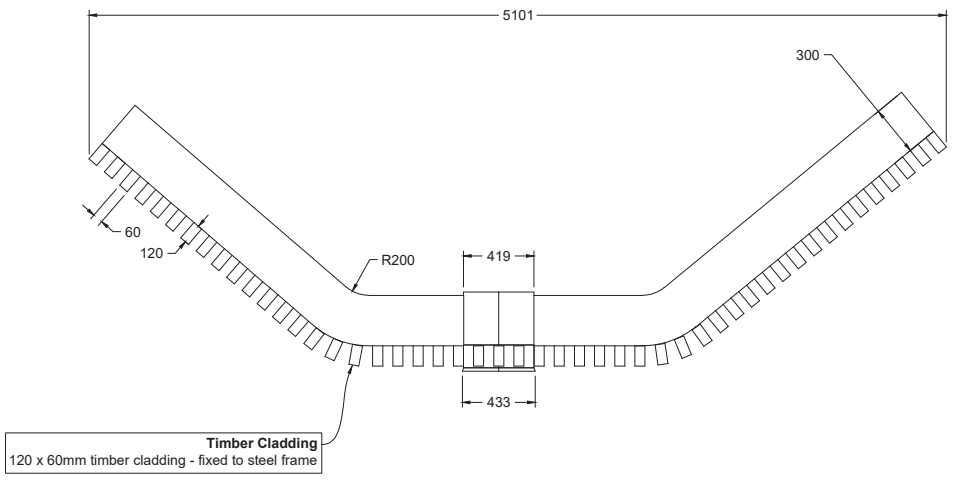
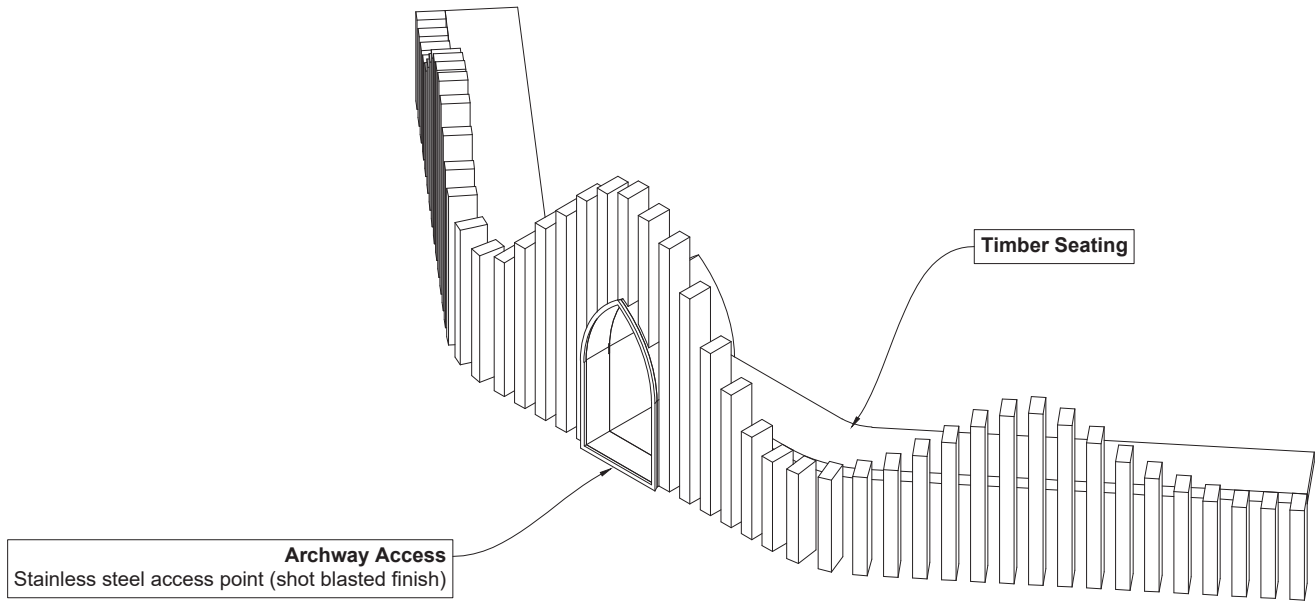



# Play Equipment **Group Swing**

## Group Swing

Product code SW.03

PLAYEQUIP

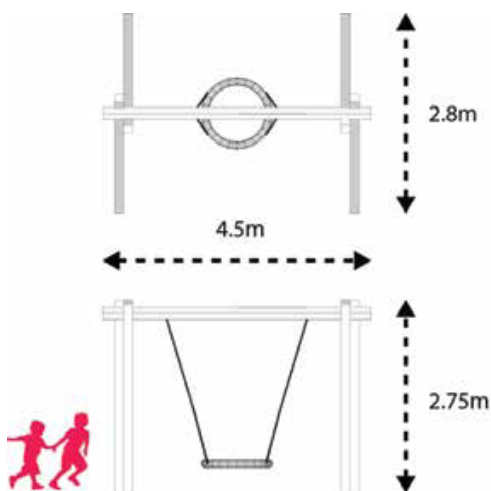

### Dimensions LxWxH (m)

4.5 x 3.4 x 2.7

CFH - 1.5

Safety Surface Area - 22 sqm

### Guarantees

Timber - 15 years

Ropes & Nets - 1 year

Fixings - 20 years

The wooden group swing is designed to allow several children to play together, including those with special needs. The swing is made from heavy duty oak beams or 200 mm diameter robinia poles, stainless steel swing fixings and can be supplied with a variety of cradles depending on your needs. We supply super durable chain cradles, steel core rope cradles and soft rope cradles in a choice of colours. A great piece of wooden playground equipment for a natural playground.

# Play Equipment Nursery Swing

## Nursery Swing

Product code SW.02

PLAYEQUIP

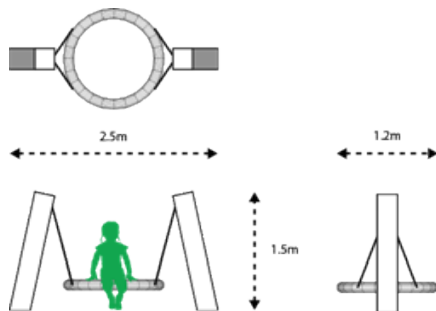

### Dimensions LxWxH (m)

2.5 x 1.2 x 1.5

CFH - 1.2

Safety Surface Area - 15 sqm

### Guarantees

Timber - 15 years

Ropes & Nets - 1 year

Fixings - 20 years

The nursery school swing allows several younger children and toddlers to play together, including those with special needs. The swing is made from heavy duty oak beams, stainless steel swing fixings and a soft and durable cradle. The unique contemporary design of this swing makes it the perfect wooden swing for toddlers and smaller children in nurseries and gardens.

# Play Equipment **In-ground trampoline**

## Playground Trampoline (Round)

Product code PT.01

PLAYEQUIP



More sizes available.

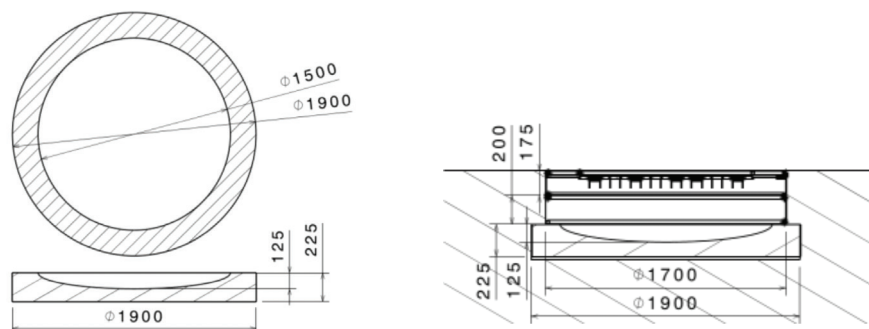

Our mini playground trampoline is a really fun way to exercise and have a great time at the same time. It's highly durable components make it a fantastic feature to any playground, school or garden. Designed to be flush with ground level, the trampoline fits discreetly into any environment until discovered.

### Outdoor In-Ground Playground Trampoline Features

- Variation of sizes of jumping surface to suit your space
- EN-1176 Safety Standard
- Durable for public space use
- Lifiable top to allow cleaning

#### Dimensions LxWxH (m)

Jumping area from  $\varnothing 1.2\text{m}$   
External from  $\varnothing 1.7\text{m}$

CFH - 1.2

Safety Surface Area - from  
22sqm

# Play Equipment **Jungle Trim Trail**

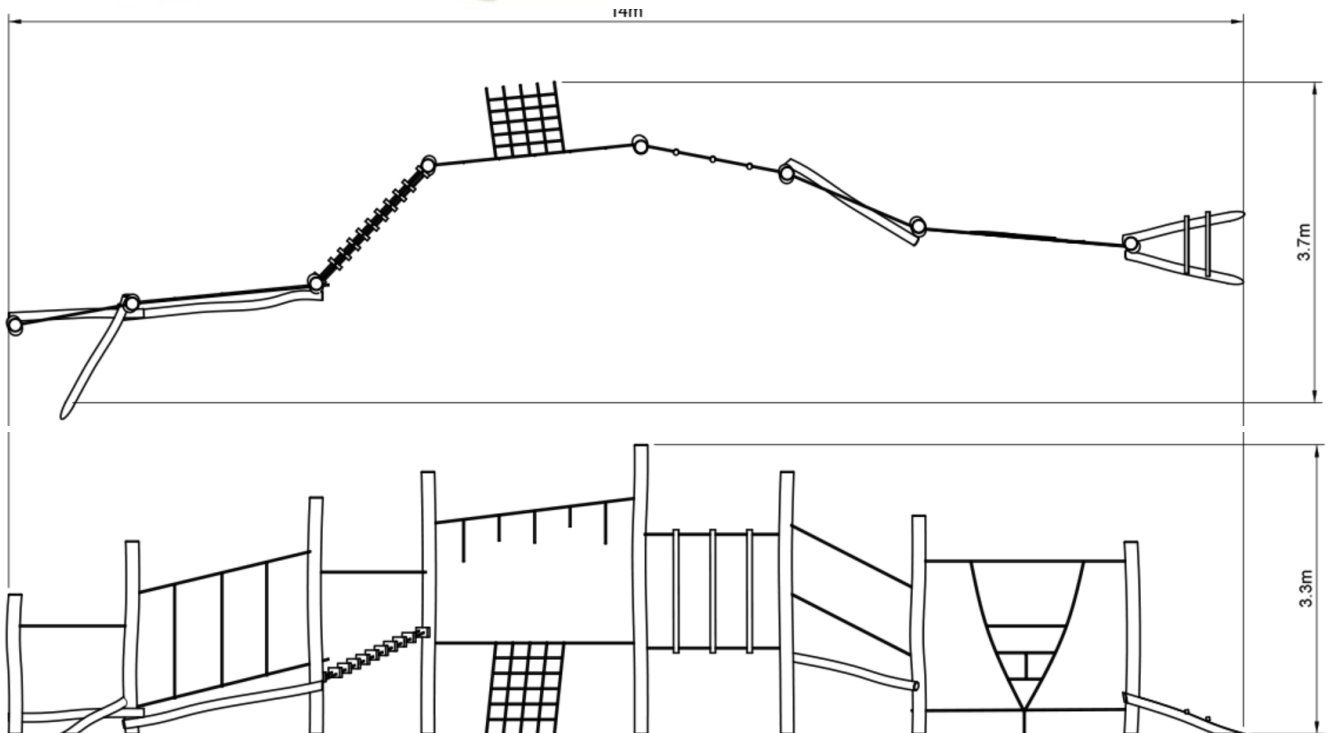

Introducing the Jungle Trim Trail, an ultimate playground challenge meticulously crafted from high-quality robinia hardwood. This adventure-packed experience seamlessly blends various ropes and timber bridges, promising endless fun for all.

Built with durability in mind, the Jungle Trim Trail features a robust construction with anti-vandal stainless steel fixings. This ensures longevity, making it a lasting investment that stands up to the test of time.

More than just a play structure, the Jungle Trim Trail is a statement of quality and craftsmanship. Designed to captivate and endure, it elevates your play space with dynamic and resilient additions, guaranteeing both safety and

boundless entertainment. Upgrade your playground with this high-quality and exciting adventure for all ages.

The nature of this construction allows it to be located around bends and not just in a straight line. Giving flexibility and a more natural aesthetic (subject to compliancy).

#### Key Features

- Stainless steel fixtures and fittings
- Naturally durable robinia hardwood (FSC®)
- Premium finish
- 16mm steel core play rope and nets

# Play Equipment **Inclusive Roundabout**

Introducing our flush-to-the-ground Inclusive Roundabout, expertly designed for effortless access and maximum safety. Ideal for wheelchair users, this addition not only enhances inclusivity but also promotes shared enjoyment. Crafted with precision, it symbolizes our commitment to safety and accessible play. Elevate your playground with this inclusive and well-designed feature.

## Key Features

- Wheel chair access
- Available seating
- Steel tread plate floor for grip
- Powder coated finish

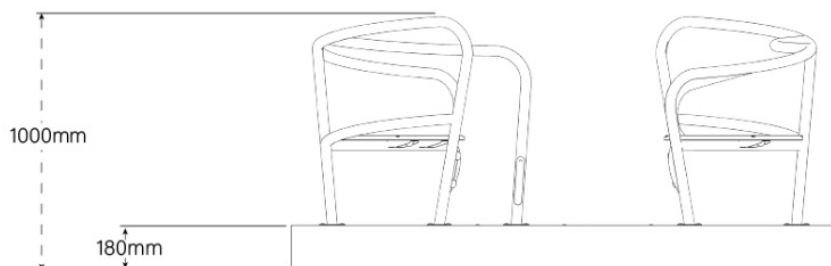
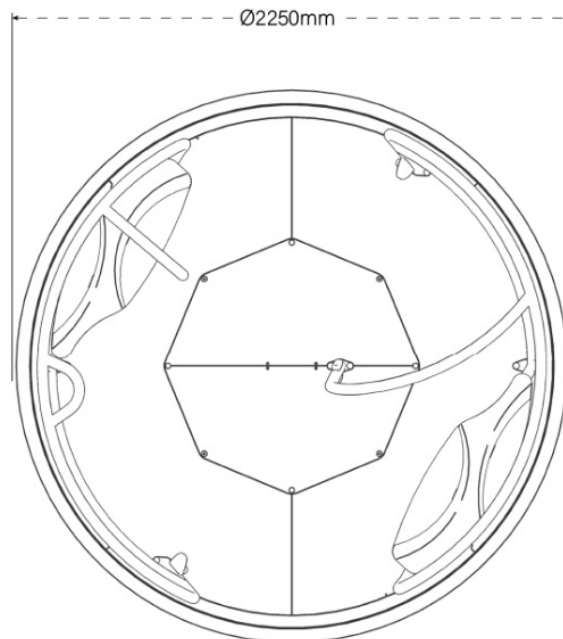

## Play Equipment **Wide Slide**



Our 1m super wide metal embankment slides are the ultimate in collaborative play slides. These slides are wide enough for 2 people to side down at once creating that extra exhilaration and excitement. We supply and install wide embankment slides at a variety of lengths with platforms ranging from 0.9m – 2.75m. All of our slides are made from stainless steel, making them durable and as vandal proof as possible.



Because of the generous width and the placing of the slide on an existing embankment, it is possible for children with reduced mobility to be assisted onto and accompanied down this slide. This has been very successful for children of all abilities in previous schemes.

# Play Equipment **Sensory Play; Activity Panel and Telephones**



The activity panel was designed to provide entertaining and stimulating activities for any playground, school, or garden. Colored spinners will enable interactive play, promoting the development of social and coordination skills.

Constructed from solid oak with stainless steel fixings, the activity panel will stand the test of time. All of the timber used FSC® certified and sourced as locally as possible.

## Key Features

- Solid oak frame for natural durability
- Anti vandal stainless steel fixings
- Interactive coloured spinners
- FSC® certified timber used

## Guarantees

- Timber – 15 years
- Fixings – 20 years



The elegant and durable stainless steel flutes are a great playground feature that gives a whole other dimension to the fun in all settings.

## Key Features

- 2 stainless steel flutes 1m high
- 15m of 30mm bend proof and pressure proof linking pipe with steel inlay (variable lengths supplied to order)

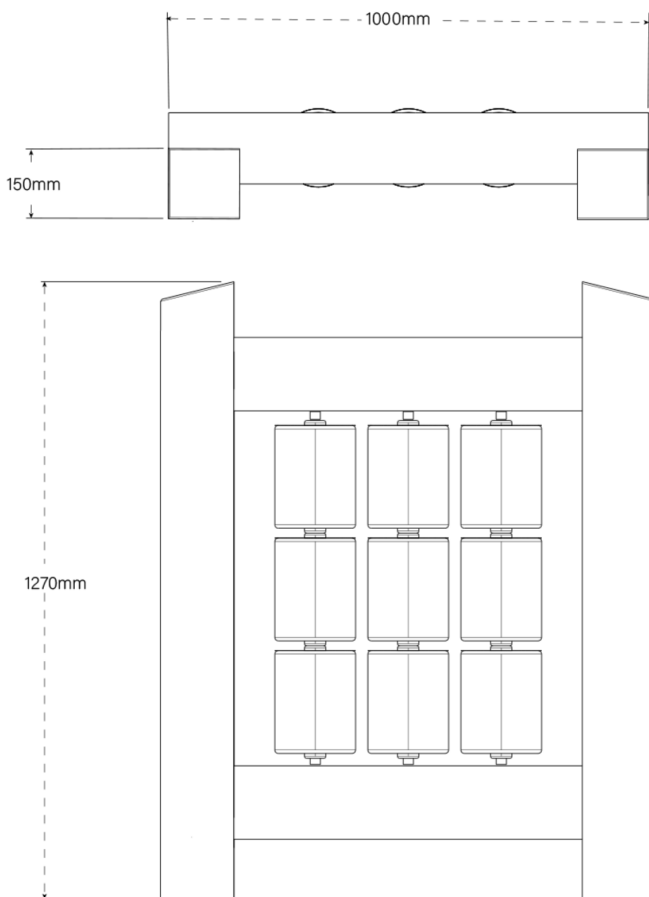

## Play Equipment **Sensory Play; Play Panel**



Maze Slide: Navigate the ball through winding paths and tricky turns in this tactile maze game. It encourages hand-eye coordination, problem-solving, and patience.

Roller Pixel: Rotate the rollers to reveal different images and patterns. It's a fun, dynamic way to inspire creativity and pattern recognition in children.

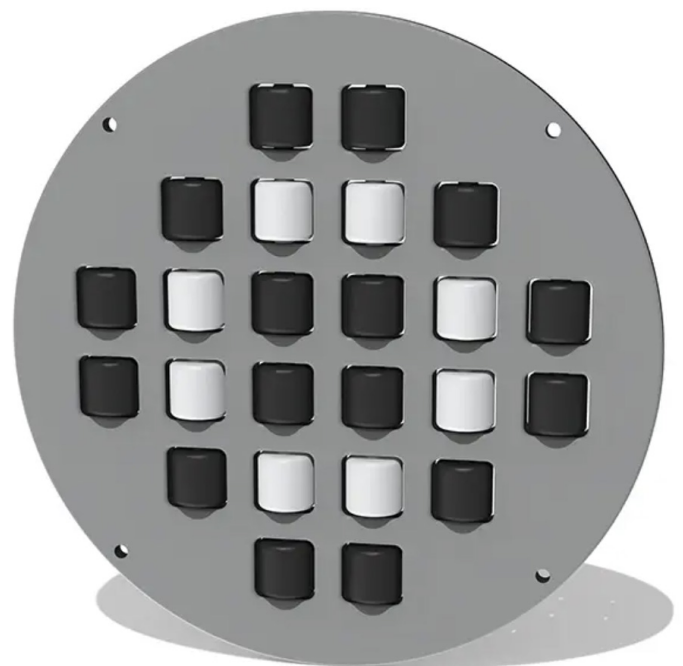

Crafted for durability, the oak frame ensures the Play Panel withstands the elements, while the inserts are designed to be low-maintenance and long-lasting. Whether installed in a public park or a private play area, the Play Panel will become a favourite spot for children to learn and play.

### Key Features:

- Sturdy solid oak frame for longevity and aesthetic appeal
- Choice of three game inserts: Maze Slide, Pattern Slider, and Roller Pixel
- Promotes cognitive development, motor skills, and creative thinking
- Suitable for outdoor use in schools, parks, or residential gardens
- Easy to maintain, with all parts designed to withstand heavy use



## Play Equipment **Journeying; Timber steps, stumps and trunk**



Timber stumps and trunk, set in Tiger Mulch play safety surface



Timber steps, set in Tiger Mulch play safety surface

# Furniture Circular Tree Bench

**Tree Bench**  
Product code PF.08

PLAYEQUIP

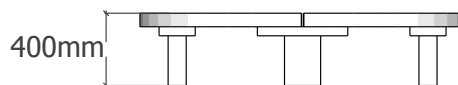
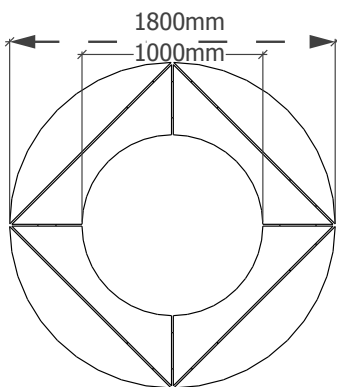

**Dimensions LxWxH (m)**  
1.8 x 1.8 x 0.4

**CFH** - 0

**Safety Surface Area** - 0 sqm

Our circular tree benches are made from premium oak and are designed to fit around any sized tree. Tree benches can make a great addition to any garden, school or public space, converting a tree into a natural rest spot.

The super robust 75mm thick oak seat makes the tree bench highly durable and suitable for spaces exposed to all types of weather.

Tree benches are also extremely easy to assemble and come with tamper proof stainless steel bolts that can be easily fixed to the ground with the stainless steel concrete mixing supplied.

## Guarantees

Timber - 15 years

Fixings - 20 years

## Planting Palette **Shade planting (below tree canopies)**



*Alchemilla mollis*



*Polystichum setiferum*



*Geranium macrorrhizum* White-Ness



*Asplenium scolopendrium*



*Geranium sylvaticum*



*Deschampsia cespitosa* Golden Veil

## Planting Palette **Pollinators and Sensory Planting**



*Lavandula angustifolia* 'Hidcote'



*Persicaria amplexicaulis* 'Firedance'



*Stipa tenuissima*

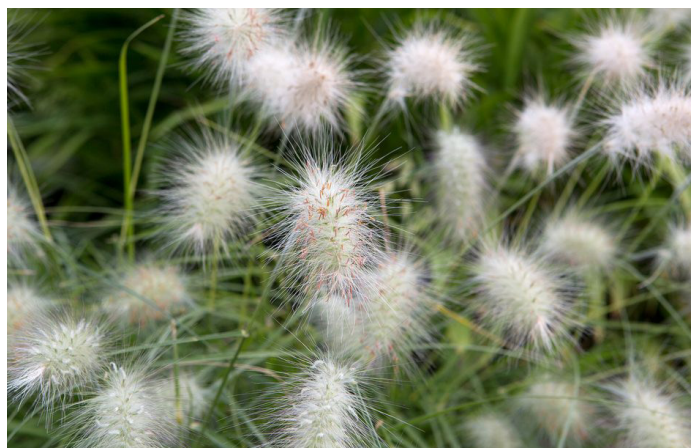

*Pennisetum villosum*

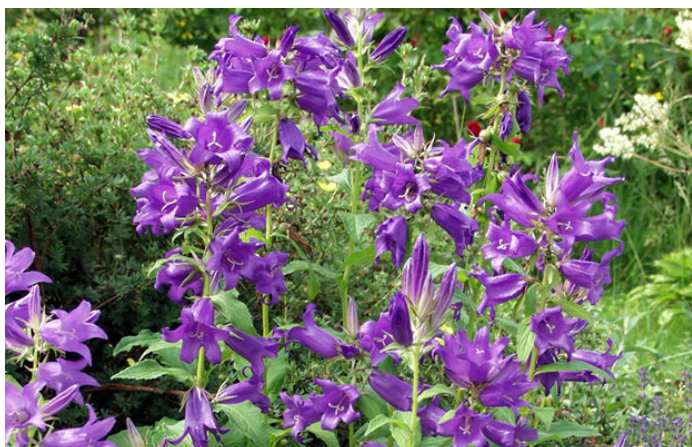

*Campanula latifolia* var. *macrantha*



*Libertia formosa*